

4-WHEEL ELECTRIC FORKLIFTS TECHNICAL SPECIFICATIONS

		Unit			
GENERAL CHARACTERISTICS	Manufacturer's type designation		CY16EF	CY18EF	CY20EF
	Drive type		Electric	Electric	Electric
	Type of operation		Seat	Seat	Seat
	Load capacity/rated load	Q kg	1.600	1.800	2.000
	Load centre distance	c mm	500	500	500
	Load distance, centre of drive axle to fork frame	x mm	395	395	395
	Wheelbase	y mm	1.390	1.490	1.490
WEIGHT	Service weight	kg	3.215	3.315	3.425
	Axle load, front/rear	kg	4.290/525	4.530/585	4.830/595
	Axle load, front/rear	kg	1.565/1.650	1.625/1.690	1.635/1.790
TIRES and CHASSIS	Tires air - rubber		P	P	P
	Tyre size, front		18x7-8	18x7-8	200/50-10
	Tyre size, rear		16x6-8	16x6-8	16x6-8
	Wheels, front/rear (x = driven wheels)		2/2	2/2	2/2
	Track width, front	mm	975	975	975
	Track width, rear	mm	950	950	950
DIMENSIONS	Mast/fork carriage tilt forward/backward a/ 3 (°)	Derece a/b	5/7	5/7	5/7
	Lowered mast height h, (mm)	h1 mm	2.117	2.117	2.117
	Free lift	h2 mm	135	135	135
	Lift height	h3 mm	3.300	3.300	3.300
	Extended mast height	h4 mm	4.300	4.300	4.300
	Overhead load guard (cab) height	h5 mm	1.985	1.985	1.995
	Height of operator chair	h7 mm	870	870	880
	Height of coupling	h10 mm	480	480	480
	Overall length with forks	l1 mm	3.020	3.120	3.130
	Length to fork frame	l2 mm	2.100	2.200	2.205
	Overall width	b1 mm	1.140	1.140	1.140
	Fork dimensions	s/e/l mm	40/100/920	40/100/920	40/100/925
	Forks type		2A	2A	2A
	Fork frame width	b3 mm	970	970	970
	Ground clearance, under mast	m1 mm	82	82	92
Ground clearance, centre of wheelbase	m2 mm	95	95	105	
PERFORMANCES	Aisle width for pallets 1000x1200 crossways	Ast mm	3.285	3.375	3.385
	Turning Radius	Wa mm	1.690	1.780	1.790
	Travel speed, loaded/unloaded km/h	(48V) km/s	16	16	16
		(36V) km/s	-	-	-
	Lift speed, loaded/unloaded m/s	(48V)mm/s	410/550	410/550	410/550
		(36V)mm/s	-	-	-
	Lowering speed, loaded/unloaded m/s	mm/s	500/450	500/450	500/450
	Drawbar pull, loaded/unloaded N	(yükklü) N	15.1	15.2	14.36
		(yüksüz) N	14.7	14.7	14
	Service brake	(yükklü) %	29.5	27.5	24.5
Park brake		Hydraulic	Hydraulic	Hydraulic	
ELECTRIC MOTOR	Drive motor performance S2 1 hr	(24V/32V) kW	5.2 / 7.1	5.2 / 7.1	5.2 / 7.1
	Pump Engine Performance	(30V) kW	15.8	15.8	15.8
	Battery Voltage at nominal capacity	Ah	625	625	625
	Battery weight	kg	860	860	860
	Battery dimensions	mm	628/827/630	628/827/630	628/827/630
OTHER DETAILS	Drive control type		AC	AC	AC

CY16EF/18EF/20EF MAST TECHNICAL SPECIFICATIONS

Lift Type	Mast lowered Height (mm)	Max Mast Height (mm)	Free-Lift (mm)		Mast tilt, backward / forward		Capacity table without sideshift,(kg) c = 500 mm			Capacity table with sideshift,(kg) c = 500 mm			Approx. Total Wgt. of Standard Equipped Truck w/o Load			
			With Protective	Without preservative			16EF	18EF	20EF	16EF	18EF	20EF	16EF	18EF	20EF	
			16/18/20EF	16/18/20EF	16/18/20EF	16/18/20EF	Forward	Back	16EF	18EF	20EF	16EF	18EF	20EF	16EF	18EF
Two-stage Mast	CDE250	1,730	2,530	135	135	5	7	1,600	1,800	2,000	1,500	1,700	1,900	3,170	3,270	3,380
	CDE270	1,830	2,730	135	135	5	7	1,600	1,800	2,000	1,500	1,700	1,900	3,190	3,290	3,400
	CDE300	1,970	3,030	135	135	5	7	1,600	1,800	2,000	1,500	1,675	1,895	3,210	3,310	3,420
	*CDE330	2,120	3,325	135	135	5	7	1,600	1,800	2,000	1,500	1,650	1,890	3,215	3,315	3,425
	CDE400	2,480	4,030	135	135	5	7	1,600	1,800	2,000	1,500	1,650	1,890	3,250	3,350	3,460
	CDE450	2,830	4,530	135	135	5	5	1,550	1,750	1,950	1,450	1,600	1,840	3,290	3,390	3,500
	CDE500	3,080	5,030	135	135	5	5	1,500	1,700	1,900	1,400	1,550	1,790	3,330	3,430	3,540
Three-stage Mast	CTE370	1,780	3,740	780	1,280	5	5	1,600	1,800	2,000	1,500	1,700	1,900	3,330	3,430	3,540
	CTE400	1,870	4,040	880	1,380	5	5	1,600	1,750	1,950	1,500	1,650	1,850	3,250	3,450	3,560
	CTE430	1,980	4,340	980	1,480	5	5	1,600	1,750	1,900	1,500	1,650	1,800	3,370	3,470	3,580
	CTE450	2,080	4,540	1,080	1,580	5	5	1,500	1,700	1,900	1,400	1,550	1,790	3,390	3,490	3,600
	*CTE470	2,130	4,740	1,130	1,630	5	5	1,450	1,650	1,850	1,350	1,500	1,740	3,450	3,550	3,680
	CTE500	2,230	5,040	1,230	1,730	5	5	1,400	1,600	1,800	1,300	1,450	1,700	3,500	3,600	3,730
	CTE550	2,430	5,540	1,430	1,930	5	5	1,375	1,425	1,750	1,300	1,350	1,650	3,520	3,620	3,750
	CTE600	2,630	6,040	1,630	2,130	5	5	925	1,000	1,400	900	930	1,275	3,550	3,650	3,780
	CTE650	2,830	6,540	1,830	2,330	5	5	900	950	1,300	820	900	1,225	3,570	3,670	3,805
	CTE700	3,030	7,040	2,030	2,530	5	5	700	650	900	600	600	850	3,590	3,590	3,825

* STANDART

* Ceylift constantly improve the products and will be updated. Therefore, from the description and specifications contained in this catalog without reserves the right to offer different products. Technical specifications are subject to change without notice. For more information, please contact your Ceylift dealer.

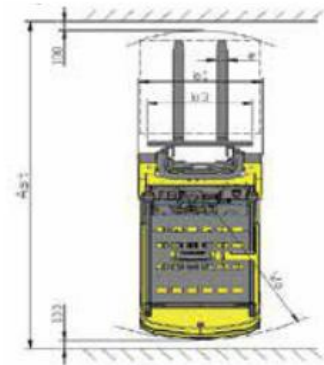
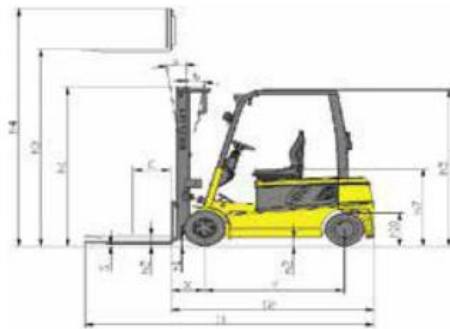

CY16EF

CY18EF

CY20EF

